

[white paper]

eicon
technology
corporation

Consolidating SNA and TCP/IP
A White Paper on Desktop DLSw™

May, 1996

Abstract

This document highlights some of the problems that MIS has faced with maintaining parallel SNA and IP networks, and how Data Link Switching (DLSw) has evolved as a solution to those problems. As well, it briefly goes into the history and contents of the Request for Comments (RFCs) that define DLSw.

It then proceeds to explain the benefits of Eicon Technology's Desktop Data Link Switching (Desktop DLSw™) solution in its Access for Windows, and Aviva - Mainframe Edition products, as well as offer several applications scenarios for the solution. Finally, a "Questions and Answers" section rounds it off by going into specific details and possible user questions.

Wendy Shetler

Product Marketing Manager, Host Access BU

Table of Contents

ABSTRACT 1

TABLE OF CONTENTS 2

INTRODUCTION 3

PC-TO-HOST CONNECTIVITY..... 3

SNA AND TCP/IP ON THE WIDE AREA NETWORK..... 3

RATIONALIZING PARALLEL NETWORKS 5

DESKTOP DLSW™: AN OPEN ALTERNATIVE..... 6

EXAMPLES OF DESKTOP DLSW™ APPLICATIONS ERROR! BOOKMARK NOT DEFINED.

CONSOLIDATING THE BACKBONE PUSHING SNA TO THE GLASS HOUSE AND THE DESKTOP..... 8

DIAL-UP DLSW: ELIMINATING THE MIDDLEMAN..... 9

DON'T WORRY ABOUT THE LOOP. ETHERNET AND REDUNDANT NETWORKS..... 9

ELIMINATING ROUTER DEPENDENCE..... 10

USING A SINGLE STACK FOR ALL NETWORKING 11

MAKING MANAGEMENT EASIER..... 11

BACKUP CONNECTIONS WITHOUT COMPROMISE..... 12

TAILORING THE INDIVIDUAL BALANCE OF SNA AND TCP/IP TRAFFIC..... 12

FUTURE IMPLEMENTATIONS OF DESKTOP DLSW 12

DESKTOP DLSW QUESTIONS AND ANSWERS 13

CONCLUSION 18

Introduction

PC-to-Host Connectivity

The modern office PC has emerged as a client for host connectivity and as an application platform in its own right. Typically, organizations began their adoption of computing by using legacy systems such as IBM mainframe and midrange hosts. But the broad deployment of personal computers in large organizations has led to a consolidation of networking, application, and terminal functions on the desktop.

In the beginning, host connectivity was designed in much the same way as the terminals it replaced. Early implementations (such as coaxial cable connections to cluster controllers) did not allow PCs to access LAN and WAN resources. SNA networks were distinct from LAN and internetworking devices at this stage.

Modern host connectivity architectures such as client-server treat SNA-based resources as another network device, along with SQL servers, mail gateways, LAN-based faxes, and printers. Host access is provided via a gateway, router, or direct connection. In these client-server architectures, distributed computing is a reality and access to corporate information resources is widely available throughout the organization.

SNA and TCP/IP on the Wide Area Network

MIS is at a crossroads. Faced with demands for increased access to information and hard-to-manage parallel networks, corporate networking infrastructures are changing. This paper will look at some of these trends, and then examine how Desktop Data Link Switching (Desktop DLSw) can resolve some of the problems they present.

In traditional corporate environments, SNA traffic and TCP/IP traffic have existed in parallel. The SNA and TCP/IP networks have each evolved their own leased line connections, management tools, and architectures. This means more for MIS to manage, and greater costs overall. As a result, organizations are looking at ways of rationalizing these redundant networks and migrating to client-server environments from older master-slave architectures.

In addition to this pressure to reduce management loads, the penetration of client-server architectures in large organizations brings with it the promise of increased competitiveness, more accessible information, and distributed access to data. This leads to a greater visibility for internetworking protocols such as TCP/IP, especially in the back office environment.

Analysts believe that TCP/IP's role in business internetworking is just beginning. The Meta group believes that , "network professionals will become key corporate systems integrators, tying together Internet services, security, and remote access..."¹. Meta believes that "TCP/IP will evolve into a universal transport protocol for multivendor distributed computing and obviate multiprotocol backbones. Server and networks operating systems will converge, leveraging APIs and RPCs from open network computing environments."²

In fact, META's bottom line is that "With address scalability and administration solutions, and imminent commoditization of OS-level integration, TCP/IP remains the protocol of choice for large, heterogeneous networks."³

For some organizations, the benefits of consolidating SNA and TCP/IP backbone networks in order to reduce the cost of owning and managing multiprotocol networks are compelling. For others, the demands of mission-critical host applications justify the increased effort in managing parallel, distinct networks.

Furthermore, the presence of dialup networking protocols (such as PPP) and the availability of desktop-based WAN protocols (like TCP/IP) have made remote access and remote LAN nodes a reality. Demand for telecommuting and teleworking solutions further fuels these trends. But until now, complete remote SNA host connectivity still required dialing into a remote LAN, and then connecting via a gateway to a host.

¹ META Fax, January 3, 1995

² META Global Networking Strategies, November 30, 1994, File 324

³ META Global Networking Strategies, November 30, 1994, File 324

Rationalizing Parallel Networks

There have been several attempts to provide access to SNA in single-network backbones, including multiprotocol routers, and adoption of a 3270/5250 version of the Telnet protocol. Initially, the tn3270/tn5250 protocols were an attempt to connect remote PCs to hosts over TCP/IP networks via Telnet servers or host-based TCP/IP stacks. But tn3270 and tn5250 did not provide the end-to-end SNA integrity that MIS needed. For example, they did not allow 5250 printing (printing is now available through extensions in 3270 environments) No provision for peer-to-peer networking existed, and there was no handling of prioritization outlined in a TN-based environment.

DLSw was proposed by IBM in RFC 1434 in March 1993. It outlines a protocol for bringing up, maintaining, and tearing down a tunnel between two TCP/IP routers, allowing SNA to travel in its native form between the two points within TCP/IP.

Over the last three years, IBM's proposal has been embraced by every major router vendor, including Proteon, Bay Networks, Novell, 3Com and Cisco. Many of the technical obstacles have been overcome, and all these vendors have introduced initial DLSw-enabled products.

In April 1995, another proposal, RFC 1795, was presented jointly by the APPN Implementer's Workshop (AIW) and the DLSw Related Interest Group (sponsored by IBM). This proposal fixed documentation problems with the existing RFC 1434, and enhanced the protocol by adding new functions and features such as support for prioritization, capability exchange, and pacing and flow control between routers. Currently, only Cisco and Proteon support RFC 1795*.

DLSw is an open standard that has been widely adopted by router vendors like IBM, Proteon, Bay Networks, 3Com, Novell and Cisco. Many of these vendors are also producing channel-attached routers which connect directly to an SNA host.

* As of April, 1996. This is subject to change as router vendors add that support to their DLSw routers

DLSw encapsulates native SNA within TCP/IP, making it routable while retaining its SNA advantages. Since its initial proposal three years ago, it has continued to evolve into a standard which addresses many of the initial problems of using SNA across a wide-area network (WAN).

DLSw addresses many of the problems found in Source Route Bridging (SRB) such as:

- Unlike SRB, it doesn't send supervisory frames (overhead traffic) across the WAN
- Supports link failure re-routing that allows fault tolerance in the case of a broken connection, allowing a continued connection when a link is broken as long as another path exists (this functionality is already inherent in IP routing).
- Flow control is a core element of the DLSw specification. It was added by the DLSw Related Interest Group (RIG) at the AIW. It allows devices at each end of the connection to negotiate transmission reductions rather than dropping packets of data and retransmitting them later.
- Extension beyond the seven ring/eight bridge limitation of source-route bridging.
- The ability to negotiate extensions to the specification, making it RFC-compliant but also open to individual vendors' enhancements.

There are some situations in which router-based DLSw is not ideal, however. Upgrading entire networks to support DLSw can be an expensive proposition. As well as the upgrade to DLSw itself, maintenance and installation costs can also be extremely expensive.

This is especially true when equipment from multiple vendors is involved in a backbone network, as compatibility issues and upgrade availability become a concern. Finally, providing a DLSw-capable TCP/IP router at every remote location may be prohibitively expensive, especially for an organization with large numbers of telecommuters or small branch offices.

Desktop DLSw™: An Open Alternative

To address these needs, Eicon Technology includes native DLSw support in its desktop emulation products including Eicon Access for Windows and Aviva - Mainframe Edition for Windows 95 and Windows NT hereby after referred to as AFW and Aviva.

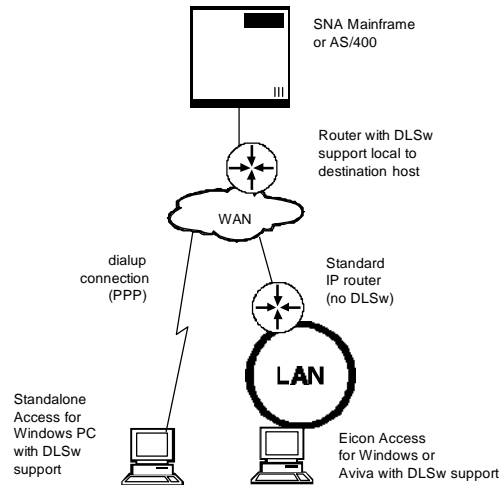

This means users will be able to connect their PCs directly to the DLSw router next to the SNA host, using only an existing standard TCP/IP router at the remote location. As the diagram at right shows, this technology – called Desktop DLSw– gives MIS an extremely flexible, TCP/IP-based networking implementation. It maintains the integrity and functionality of native SNA, but it can be deployed in a variety of environments where router-based DLSw is not practical.

For example, in remote access environments, or in small branch offices where TCP/IP routers with DLSw are unavailable.

For dialup connections, no intermediate routers or gateways are needed. For regional offices with non-DLSw routers, only one router – the one closest to the destination mainframe or midrange computer – will need to support DLSw. All other routers in the organization only need to provide standard IP routing.

Examples of Desktop DLSw™ Applications

Desktop DLSw allows native SNA to reach out to remote users and small regional offices, but at the same time pushes SNA back to the mainframe “glass house.” This both consolidates backbone network traffic and makes client-server deployment of legacy-based information easier. The following examples outline some of the ways Desktop DLSw increases the options available to MIS.

Consolidating the Backbone: Pushing SNA to the Glass House and the Desktop

By replacing existing boundary routers with DLSw-enabled routers (or upgrading them,) organizations can push SNA out of the WAN. SNA traffic travels from the client PC to the DLSw-enabled boundary router in an SNA link-level protocol (such as 802.2.) The DLSw router removes the 802.2 information and replaces it with TCP/IP information, and sends it to the destination DLSw router.

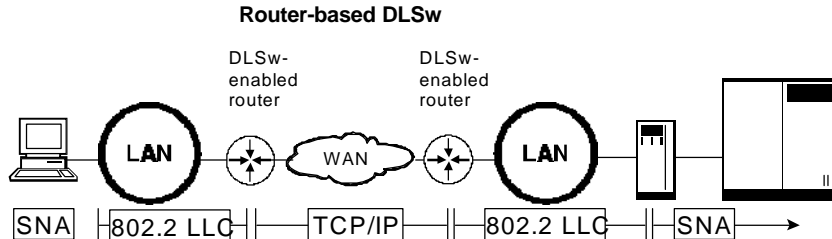

The above approach has one inherent problem in that replacing or upgrading boundary routers can be time consuming and a costly proposition. One way to solve this problem is to move DLSw to the desktop. Eicon’s Desktop DLSw support means the client PC transmits the SNA information inside TCP/IP packets. Only one router needs to be upgraded to support DLSw - the central site router. And, only one protocol comes out of the PC – TCP/IP. There is 50% less overhead created by adding and removing 802.2 headers and trailers.

By doing this, MIS is able to reduce the number of network protocols they support. Settling on TCP/IP as a LAN and WAN protocol reduces support costs and greatly simplifies network management.

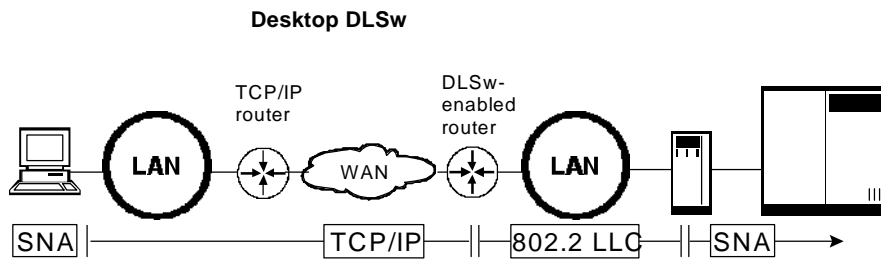

Dial-up DLSw: Eliminating the Middleman

Desktop DLSw support enables dial-up access to routers using Point-to-Point Protocol (PPP) connections. This allows remote access applications to talk directly to the DLSw router without a gateway in the connection.

With Eicon's Desktop DLSw, users can connect directly to a DLSw-enabled router local to the host without going through additional LAN servers, gateways, or routers. This solution does not compromise SNA (as is the case with tn3270 and tn5250) allowing all types of SNA traffic – including Peer-to-Peer, mainframe, and midrange connections.

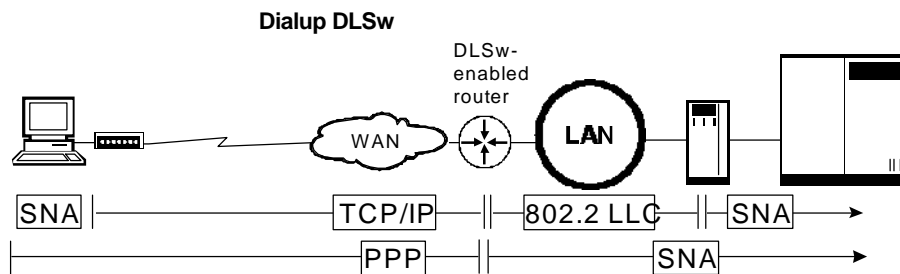

Desktop DLSw is a ubiquitous solution which allows users to dial up asynchronously into an IBM mainframe or midrange computer with no intermediate gateway. The client software uses the same technology as it does when connecting to the Internet or a remote LAN.

Don't worry about the loop: Ethernet and redundant networks

Most DLSw-enabled routers do not support DLSw on Ethernet. Others, like the IBM 6611, allow Ethernet but do not have any mechanism to prevent loops. The DLSw Special Interest Group (SIG) did not address the issue in revision 1 of their RFC because of the complexity of looping issues, but they plan to address it in revision 2.

With router-based DLSw, users need a token ring LAN in the remote office – at the very least – between the SNA “TIC” gateway and the DLSw router. If the organization wants to run full-stack 802.2 on the every client PC directly to the DLSw router, token ring is needed on all workstations. If you want to use a router that allows Ethernet connections, you must be sure that your network does not and *will* not have any loops. A network without possible loops means a very simple network without any fault-tolerance or redundant paths.

With Desktop DLSw, SNA clients do not use 802.2 – instead, they send out packets of Switch-to-Switch Protocol (SSP) information on TCP/IP. As a result, you do not need token ring in the branch office. Because information comes from the workstation, there is no propagation of the explorer that exists in a router-based solution – and no loops are possible. Desktop DLSw allows users to employ Ethernet in complex, redundant, fault-tolerant branch office LANs and keep Token Ring in the glass house at the central site. The obvious cost and time savings of using an existing Ethernet solution rather than changing to a more expensive token-ring one make this a significant advantage for MIS.

Eliminating Router Dependence

Moving DLSw to the desktop removes dependence on the router. This is especially useful in large, multi-vendor networks where DLSw support has not been rolled out across the entire organization and where the limited features of a Telnet-based solution are not enough.

Because DLSw is an open specification, corporations can choose their central-site router from a variety of vendors such as IBM, Novell, Cisco, Proteon, Bay Networks, Ascom Timeplex, and 3COM. The router can be linked via either a direct LAN or channel-attached connection. Desktop DLSw provides simultaneous support for both RFCs (1434 and 1795), and so corporations with heterogeneous router networks can implement the solution across the enterprise. This means that if a corporation has both Cisco (RFC 1795) and Bay Networks (RFC 1434) DLSw routers on their network, simultaneous sessions over Desktop DLSw connections (3270, 5250 and APPC) are supported with both brands. At the branch office level, only generic IP routers, **not** DLSw routers are needed. This means that generic TCP/IP routers can function as “feeder” routers for transmitting the TCP/IP to the backbone from the boundary LANs, providing MIS with flexibility needed in their network designs.

Using a Single Stack for all Networking

In router DLSw environments, LAN-based SNA traffic (802.2 LLC) is sent to the router, which strips off the 802.2 LLC headers and replaces them with TCP/IP. The router at the other end removes the TCP/IP headers and replaces the SNA Link Level headers (typically 802.2.)

With Desktop DLSw, however, the SNA is encapsulated directly into TCP/IP on the desktop with no loss in performance or memory usage (when compared with the 802.2 used in traditional SNA networks.) The only traffic the client PC transmits is TCP/IP for its LAN, WAN and SNA inter-networking. The use of 802.2 LLC at the remote location is eliminated completely.

The SNA traffic can use the same TCP/IP stack as other applications on the desktop, so each client only needs one stack – TCP/IP – for all its LAN, WAN and SNA traffic.

Making Management Easier

For an office using Desktop DLSw and a non-DLSw (standard TCP/IP) router, MIS manages only one DLSw-enabled router per SNA destination, and this router is at a central location where it is connected to the host (either by a channel attachment or a traditional SNA link-level protocol like 802.2, SDLC, or Frame Relay.) As a result, management costs, training times – and even travel costs – are cut drastically. And no change to the backbone router network is needed.

The administration of TCP/IP addressing in a Desktop DLSw environment is no more complex than setting up a tn3270-style connection. Eicon's Desktop DLSw implementation doesn't require static IP addresses to be allocated to the workstations. And with the Internet Engineering Task Force's support for Dynamic Host Control Protocol (DHCP), managing TCP/IP addressing issues is made even simpler.

Backup Connections Without Compromise

A Desktop DLSw connection also has useful implementations as a backup connection for mission-critical applications.

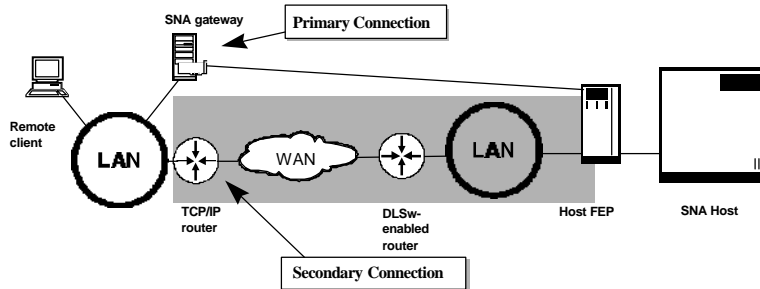

Users may use an SNA gateway as a default connection in a parallel backbone network. Should the gateway connection become unavailable, resuming a true SNA connection is as easy as opening a new session with the Desktop DLSw connection. This connection takes place across a native SNA connection using the parallel backbone router network.

Tailoring the Individual Balance of SNA and TCP/IP Traffic

The DLSw specification allows for negotiation of custom features such as prioritization and optimization techniques. RFC 1795 includes prioritization, so with a Desktop DLSw connection, prioritization is supported at this time only with Cisco or Proteon routers.

Future Implementations of Desktop DLSw™

As users demand TCP/IP stacks on the desktop for access to Internet-based resources and vendors ship TCP/IP stacks as integral components of major operating systems, the deployment of Desktop DLSw becomes an increasingly useful tool for MIS.

Other implementations emerge when we consider emerging technologies. For example, in ATM-based connections where ATM LAN emulation is used there is no way of employing a router on the client side. But with DLSw on the desktop, Eicon's remote SNA client can connect across a wide area network to a host-side DLSw device adjacent to the destination host. As TCP/IP reaches more and more back office desktops, the number of implementations will grow.

Desktop DLSw™: Questions and Answers

The following are some common questions about this connection type, along with answers that explain the impact of a Desktop DLSw connection and the rationale behind this release.

Q — Why do you support tn3270 in AFW with extended attributes as well, if Desktop DLSw is so much better?

- Eicon aims to provide a solution which fits whatever configuration matches the needs of the organization. It's true that DLSw can replace tn3270 by simply swapping out a terminal server and replacing it with a DLSw-enabled router, and this is a quick way to move from Telnet-based connections to native end-to-end SNA. But we offer both as standard features so we can work in as many environments as possible. In fact, Eicon's implementations of tn3270 and tn5250 are more complete than anyone's, including broader TCP/IP stack support, integrated host graphics, and more.

Q — Aren't I adding a stack with TCP/IP-based connections?

- Desktop DLSw is aimed at companies for whom TCP/IP plays an important part in their networking. If the organization isn't already using TCP/IP for Internet access, SQL support, or things like that, the answer is yes. By analysts' projections show TCP/IP penetrating the enterprise almost completely in the coming years. But this is really a moot point. Desktop DLSw is a solution that provides better support of SNA for organizations which want to settle on TCP/IP as a LAN, WAN and SNA transport protocol. Deciding between SNA and TCP/IP on the WAN is something administrators have to do based on the needs of their organization – and Eicon's AFW and Aviva products support both decisions.

Q — Does Desktop DLSw use up more processing on the desktop than comparable solutions?

- Desktop DLSw uses less CPU cycles than an 802.2 LLC connection to a local host. In the case of 802.2 LLC, the 802.2 drivers must be loaded (e.g. DxM) for host access. In addition, TCP/IP drivers for TCP/IP applications like Internet access must be loaded. With a Desktop DLSw connection, only the TCP/IP drivers must be loaded.

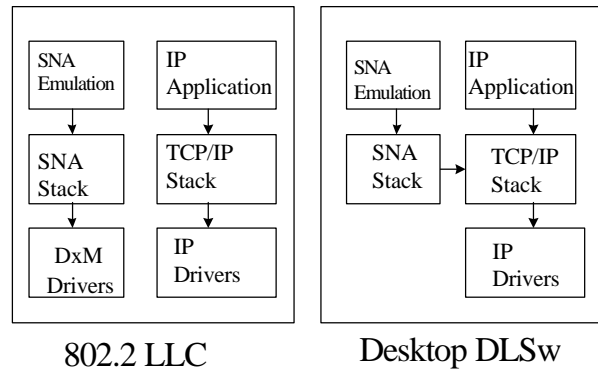

It's important to remember that this is a solution for companies that *want* to settle on a single WAN protocol – TCP/IP – and use this as a desktop protocol for client-server applications. And remember that in router DLSw, the router has to remove the SNA transport layer information, replace it with TCP/IP, transmit it, and the receiving router has to reverse the operation.

Q — Is Desktop DLSw just for 3270?

- No. While tn3270 supports only 3270 by definition, encapsulation allows transmission of any SNA traffic across TCP/IP – including peer-to-peer networking (LU 6.2), 5250 printing, and so on.

Q — What kind of overhead are we talking about here?

- In an environment where TCP/IP and SNA stacks are already in use, none. It's important to remember that these are Windows stacks, so they're DLL- or VXD-based, and don't affect low DOS memory. It's also less overhead than tn3270.

Q — Why is this better than a Telnet-based solution?

- For lots of reasons. It supports peer-to-peer architectures like LU6.2. It includes support for 5250 printers. It requires overhead. It doesn't require a dedicated terminal server. It's native SNA, end-to-end. And unlike TN servers, there's no associated per-LU charge involved in connecting users.

Q — Is it really as simple as SNA inside TCP/IP?

- In fact, DLSw uses a protocol called Switch-to-Switch Protocol (SSP.) This is what allows the SNA information to reach the remote host correctly. For more information on the technical aspects of DLSw and Eicon's Desktop DLSw, contact your local Eicon representative, visit the following URLs -
<http://www.raleigh.ibm.com/app/aiwinfo/aiwsites.htm>, or
<http://www.eicon.com/product/wpapers>. Or, consult RFC 1434 and/or 1795, which outlines the technical elements in more detail.

Q — Don't router vendors already offer SNA encapsulation schemes with their existing products?

- Yes. And AFW or Aviva will work with those, using for example its existing 802.2 LLC support. But in a heterogeneous environment, it's unlikely that any acceptable level of interoperability can be reached. This is where Desktop DLSw comes in – by providing DLSw on the client PC, administrators are not subject to the availability of technology from a range of vendors. MIS can use AFW or Aviva on the desktop with a Desktop DLSw connection to the host even if their router networks consists of routers from different vendors. Some router vendors support only RFC 1434, and others support only RFC 1795. Desktop DLSw works with both, and it supports them both simultaneously. This means that users can have multiple sessions to multiple host types (mainframe and midrange and peer-to-peer connections) through multiple router vendor's products concurrently. Eicon AFW and Aviva's Desktop DLSw solutions are one of the most interoperable DLSw solutions on the market today!

Q — Since each workstation is a PU, how does this affect performance?

- The cost of managing PU concentration is climbing. As PU concentration goes into the glass house (a trend started by 802.2 LLC in the first place) full-stack solutions will prevail. Gateways are increasingly being managed from the same place as the hosts. Full stack is no longer an issue – DLSw reinforces the benefits of full-stack support. Even IBM's 3172 will remove PU limitations in the next release.

Q — How about special enhancements like DLSw+?

- The DLSw specification provides for “negotiation” or additional features between routers. This means that if both boundary routers support some feature – optimization or prioritization, for example – there are benefits to this over a standard DLSw solution.

Q — I have an environment where all the routers are from a single vendor, and they’ve all got support for proprietary SNA-into-TCP/IP encapsulation which works just fine. How do you help me?

- Eicon’s AFW and Aviva products supports this sort of configuration with our traditional 802.2, a standard feature of the products. But there are some benefits. You’re not locked into that vendor. If you want to do Electronic Data Exchange (EDI) with another company that doesn’t use the same routers, you won’t be limited by router incompatibility, for example. If you want to provide remote access via dial-up PPP into the backbone router network, you can do so. And you don’t have to manage the SNA-to-TCP/IP addressing at each boundary router.

Q — Why is a technology like this coming from a gateway manufacturer? Doesn't this eliminate the need for a gateway?

- This technology is an option for users who want a single-protocol backbone. Many organizations – like finance companies – need the reliability and maintainability of a dedicated SNA network. Those organizations haven't migrated to tn3270-style environments, and Desktop DLSw isn't for them. But for an organization that wants to settle on a single-protocol backbone (TCP/IP), Desktop DLSw is a flexible, standards-based scheme for providing true SNA – and all the advantages that entails – across the existing backbone. A large organization will need both SNA and non-SNA solutions. AFW and Aviva provide excellence and robustness in all kinds of connections: direct (802.2), gateway (InterConnect Gateway, NetWare for SAA*, Microsoft SNA Server), remote (SDLC and stand-alone), Telnet (tn3270, tn5250, with extended attributes and host graphics - AFW only) and next-generation TCP/IP connections via Desktop DLSw or router DLSw.

* Currently supported with AFW, available soon with Aviva

Conclusion

The evolution of the PC has taken it from its beginnings as a low-level application platform or terminal replacement to its current role as a consolidator of information from diverse local and remote sources.

For corporations that have embraced TCP/IP as a way of deploying client-server architectures throughout their organization, Desktop DLSw is an effective addition to the MIS toolbox. It brings native SNA to the desktop while allowing a single-protocol backbone network. It allows dialup host access and removes dependence on router vendors.

Desktop DLSw is available at no extra cost as an additional feature in Eicon Technology's AFW and Aviva product lines. It joins a broad suite of connection types currently available in the SNA client software which allow users to access hosts across a variety of gateways.

Eicon Technology Corporation

Tel.: (514) 745-5500
Fax: (514) 745-5588

**In the United States, Canada,
Latin America:**

Tel.: 1-800-80-EICON
(214) 239-3270
Fax: (214) 239-3304

In Europe, Middle East, Africa:

Tel.: +44 (0) 181 967-8000
Fax: +44 (0) 181 967-8050

In Australia, New Zealand, Asia:

Tel.: +61 (2) 9919-7200
Fax: +61 (2) 9929-6300

Internet:

North America: sales@eicon.com
Europe: sales.europe@eicon.com
Asia Pacific: sales.asiapac@eicon.com
Worldwide Web: <http://www.eicon.com/>

